

“YOUR SUPPLIER FOR REMANUFACTURED COMPRESSORS “ SONI AIRCON PVT LTD



Edition: April 2022

WHY SONI AIRCON PVT LTD!

QUALITY & PRICE.

Compared to competitors our prices are much better. You get an exact replacement and not a generic model so we can save you not only money, but time. The fact is, we are a true remanufacturer, not a rebuilder or repair shop. Don't be fooled by the competition. None of them have the same process or quality that you'll get with SONI AIRCON PVT LTD.

MISSION

Our goal is to provide our customers with high quality equipment with longevity, the latest industry protection devices available, and a comprehensive installation package. This will lead to a smooth and easy installation, lack of short-term failure, and low replacement rate.

INDUSTRY LEADING WARRANTY

We provide the highest quality products and to back up our claim, we are the only company that prints out actual computer run test results with our compressors. Testing is done hands-free; the computer runs the test and we show you the results.

Our high quality allows us to offer warranty coverage as well as allowing our customers to purchase extended warranty coverage up to **1 year**.

INHOUSE MANUFACTURED

FILTER DRIER **FREE** WITH COMPRESSORS

We Designed and manufacture inhouse Filter Drier and provide free along with our compressors to Protect Your System

A filter drier is designed to protect a system from moisture, acids, and solid contaminants. Moisture can clog an expansion device with ice, reduce system efficiency due to the thermodynamic properties of water, or combined with high temperatures and pressures and oils in the system, can form acids, which damage the compressor and other components. Solid contaminants can clog expansion devices and wear compressors prematurely. So quite simply, filter driers should be judged on their ability to protect the system.



DANFOSS-SM-SERIES

SCROLL COMPRESSORS

MODEL NO	SM-110
BRAND	DANFOSS
TYPE	SCROLL
DIMENSION (WXH)(mm)	558 x 284
WEIGHT (kg)	75
REFRIGERANT	R22
V/A	420V



MODEL NO	SM-120
BRAND	DANFOSS
TYPE	SCROLL
DIMENSION (WXH)(mm)	558 x 284
WEIGHT(kg)	75
REFRIGERANT	R22
VOL/CU	420V



MODEL NO	SM-147
BRAND	DANFOSS
TYPE	SCROLL
DIMENSION (WXH)(mm)	540 x 223
WEIGHT(kg)	67
REFRIGERANT	R22
VOL/CU	420V



MODEL NO	SM-148
BRAND	DANFOSS
TYPE	SCROLL
DIMENSION (WXH)(mm)	540 X 223
WEIGHT(kg)	67
REFRIGERANT	R22
VOL/CU	420V



MODEL NO	SM-160/161
BRAND	DANFOSS
TYPE	SCROLL
DIMENSION (WXH)(mm)	540 X 223
WEIGHT(kg)	67
REFRIGERANT	R22
VOL/CU	420V



MODEL NO	SM-185
BRAND	DANFOSS
TYPE	SCROLL
DIMENSION(WXH)(mm)	650 X 266
WEIGHT(kg)	104
REFRIGERANT	R22
VOL/CU	420V



DANFOSS-SY-SERIES

SCROLL COMPRESSORS

MODEL NO	SY-240
BRAND	DANFOSS
TYPE	SCROLL
DIMENSION(WXH)(mm)	690 X 354
WEIGHT(kg)	157
REFRIGERANT	R22
VOL/CU	420V



MODEL NO	SY-300
BRAND	DANFOSS
TYPE	SCROLL
DIMENSION(WXH)(mm)	701 X 344
WEIGHT(kg)	162
REFRIGERANT	R22
VOL/CU	420V



MODEL NO	SY-380
BRAND	DANFOSS
TYPE	SCROLL
DIMENSION(WXH)(mm)	726 X 344
WEIGHT(kg)	170
REFRIGERANT	R22
VOL/CU	420V



COPELAND-ZR/ZP-SERIES

SCROLL COMPRESSORS

MODEL NO	ZR-42
BRAND	COPELAND
TYPE	SCROLL
DIMENSION(WXH)(mm)	241x406
WEIGHT(kg)	30
REFRIGERANT	R22
VOL/CU	420V

MODEL NO	ZR-48
BRAND	COPELAND
TYPE	SCROLL
DIMENSION(WXH)(mm)	240x436
WEIGHT(kg)	32
REFRIGERANT	R22
VOL/CU	420V

MODEL NO	ZR-57
BRAND	COPELAND
TYPE	SCROLL
DIMENSION(WXH)(mm)	240x436
WEIGHT(kg)	35
REFRIGERANT	R22
VOL/CU	420V

MODEL NO	ZR-61
BRAND	COPELAND
TYPE	SCROLL
DIMENSION(WXH)(mm)	246x450
WEIGHT(kg)	38
REFRIGERANT	R22
VOL/CU	420V

MODEL NO	ZR-72
BRAND	COPELAND
TYPE	SCROLL
DIMENSION(WXH)(mm)	246x465
WEIGHT(kg)	42
REFRIGERANT	R22
VOL/CU	420V



MODEL NO	ZR-81
BRAND	COPELAND
TYPE	SCROLL
DIMENSION(WXH)(mm)	242x443
WEIGHT(kg)	42
REFRIGERANT	R22
VOL/CU	420V



MODEL NO	ZR-108
BRAND	COPELAND
TYPE	SCROLL
DIMENSION(WXH)(mm)	232x533
WEIGHT(kg)	59
REFRIGERANT	R22
VOL/CU	420V



MODEL NO	ZR-125/144
BRAND	COPELAND
TYPE	SCROLL
DIMENSION(WXH)(mm)	232x533
WEIGHT(kg)	61
REFRIGERANT	R22
VOL/CU	420V



MODEL NO	ZR-160/190
BRAND	COPELAND
TYPE	SCROLL
DIMENSION(WXH)(mm)	234x552
WEIGHT(kg)	64
REFRIGERANT	R22
VOL/CU	420V



MODEL NO	ZP-295
BRAND	COPELAND
TYPE	SCROLL
DIMENSION(WXH)(mm)	448x785
WEIGHT(kg)	160
REFRIGERANT	R410
VOL/CU	420V



MODEL NO	ZP-385
BRAND	COPELAND
TYPE	SCROLL
DIMENSION (WXH)(mm)	448x746
WEIGHT(kg)	167
REFRIGERANT	R410
VOL/CU	420V

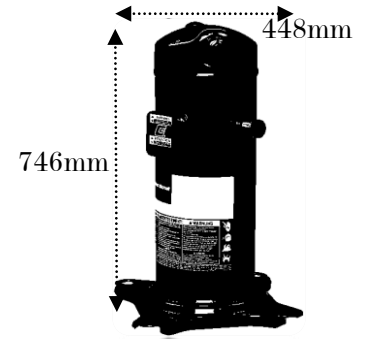

MODEL NO	ZP-485
BRAND	COPELAND
TYPE	SCROLL
DIMENSION (WXH)(mm)	448x792
WEIGHT(kg)	175
REFRIGERANT	R410
VOL/CU	420V

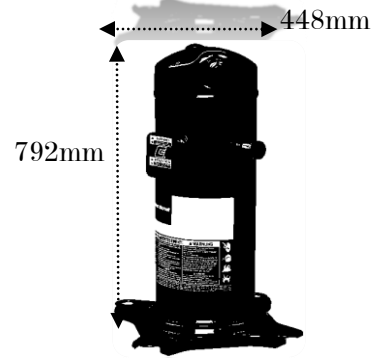

MODEL NO	ZP-235
BRAND	COPELAND
TYPE	SCROLL
DIMENSION (WXH)(mm)	367x717
WEIGHT(kg)	155
REFRIGERANT	R410
VOL/CU	420V

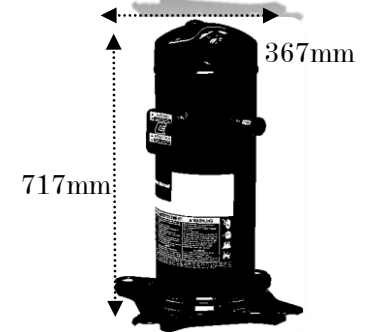

MODEL NO	ZP-182
BRAND	COPELAND
TYPE	SCROLL
DIMENSION (WXH)(mm)	242x551
WEIGHT(kg)	110
REFRIGERANT	R410
VOL/CU	420V

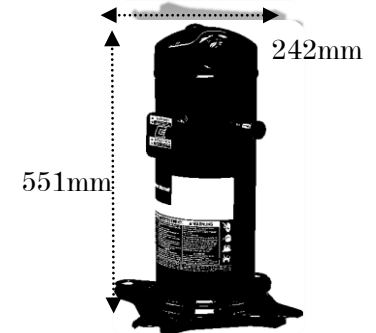

MODEL NO	ZP-154
BRAND	COPELAND
TYPE	SCROLL
DIMENSION (WXH)(mm)	242x551
WEIGHT(kg)	90
REFRIGERANT	R410
VOL/CU	420V



MODEL NO	ZP-143
BRAND	COPELAND
TYPE	SCROLL
DIMENSION (WXH)(mm)	232x533
WEIGHT(kg)	82
REFRIGERANT	R410
VOL/CU	420V

MODEL NO	ZP-122
BRAND	COPELAND
TYPE	SCROLL
DIMENSION (WXH)(mm)	232x533
WEIGHT(kg)	82
REFRIGERANT	R410
VOL/CU	420V

MODEL NO	ZP-104
BRAND	COPELAND
TYPE	SCROLL
DIMENSION (WXH)(mm)	232x533
WEIGHT(kg)	82
REFRIGERANT	R410
VOL/CU	420V

MODEL NO	ZP-104/ 91
BRAND	COPELAND
TYPE	SCROLL
DIMENSION (WXH)(mm)	245x440
WEIGHT(kg)	76
REFRIGERANT	R410
VOL/CU	420V

MODEL NO	ZP-83/72/61/54
BRAND	COPELAND
TYPE	SCROLL
DIMENSION (WXH)(mm)	185x426
WEIGHT(kg)	68
REFRIGERANT	R410
VOL/CU	420V



MODEL NO	ZP-42/36/31/29/24
BRAND	COPELAND
TYPE	SCROLL
DIMENSION(WXH)(mm)	167x245
WEIGHT(kg)	68
REFRIGERANT	R410
VOL/CU	420V



DAIKIN-JT-SERIES

INVERTER-SCROLL COMPRESSORS

MODEL NO	JT1-GCVDKYN-7525
BRAND	DAIKIN
TYPE	INVERTER-SCROLL
DIMENSION(WXH)(mm)	167x245
WEIGHT(kg)	68
REFRIGERANT	R410
VOL/CU	420V



MODEL NO	JT1-GCVDKYN@T
BRAND	DAIKIN
TYPE	INVERTER-SCROLL
DIMENSION(WXH)(mm)	167x245
WEIGHT(kg)	68
REFRIGERANT	R410
VOL/CU	420V



MODEL NO	JT15-JBVDKYN@T
BRAND	DAIKIN
TYPE	INVERTER-SCROLL
DIMENSION(WXH)(mm)	167x245
WEIGHT(kg)	68
REFRIGERANT	R410
VOL/CU	420V



MODEL NO	JT16-KCVDYR@TF
BRAND	DAIKIN
TYPE	INVERTER-SCROLL
DIMENSION(WXH)(mm)	167x245
WEIGHT(kg)	68
REFRIGERANT	R410
VOL/CU	420V



MODEL NO	JT1-GUVDYR@TF
BRAND	DAIKIN
TYPE	INVERTER-SCROLL
DIMENSION(WXH)(mm)	167x245
WEIGHT(kg)	68
REFRIGERANT	R410
VOL/CU	420V



MITSUBISHI

INVERTER-SCROLL COMPRESSORS

MODEL NO	HNB84FC1-Y
BRAND	MITSUBISHI-INVERTER
TYPE	SCROLL
DIMENSION(WXH)(mm)	167x245
WEIGHT(kg)	68
REFRIGERANT	R410
VOL/CU	420V



MODEL NO	HNB84FC1-YE-C
BRAND	MITSUBISHI-INVERTER
TYPE	SCROLL
DIMENSION(WXH)(mm)	167x245
WEIGHT(kg)	68
REFRIGERANT	R410
VOL/CU	420V



MODEL NO	ANB52FYDMT
BRAND	mitsubishi-inverter
TYPE	scroll
DIMENSION(WXH)(mm)	167x245
WEIGHT(kg)	68
REFRIGERANT	R410
VOL/CU	420V



HITACHI

INVERTER-SCROLL COMPRESSORS

MODEL NO	DA65PHD-D1YZ
BRAND	HITACHI
TYPE	INVERTER-SCROLL
DIMENSION(WXH)(mm)	167x245
WEIGHT(kg)	68
REFRIGERANT	R410
VOL/CU	420V



CONTACT US



















M/s SONI AIRCON PVT LTD

C-41, SECTOR-58, NOIDA

E-MAIL-Soniaircon@yahoo.com

Mobile:9958663438

**COMPRESSOR-SCROLL-R-407A GAS
PRICE-LIST
REFURBISHED COMPRESSOR**

SRN	MODEL/NO	MAKE	PRICE		WARRANTY	FREE
	SCROLL		With replacement of Old Compressor	With out replacement of old compressor	From date of billing/Invoice	
1	SM-84		15,134.00	23,184.00	12 MONTHS	
2	SM-90		16,215.00	24,840.00	12 MONTHS	
3	SM-100		17,296.00	26,496.00	12 MONTHS	
4	SM-110		21,620.00	33,120.00	12 MONTHS	
5	SM-120		21,620.00	33,120.00	12 MONTHS	
6	SM-147		22,770.00	34,270.00	12 MONTHS	
7	SM-148		22,770.00	34,270.00	12 MONTHS	
8	SM-161		23,920.00	44,620.00	12 MONTHS	

**COMPRESSOR-SCROLL-R-407A GAS
PRICE-LIST
REFURBISHED COMPRESSOR**







9	SM-175		23,920.00	44,620.00	12 MONTHS	
10	SM-185		30,130.00	46,230.00	12 MONTHS	
11	SY-240		56,350.00	85,790.00	12 MONTHS	N/A
12	SY-300		56,350.00	85,790.00	12 MONTHS	N/A
13	SY-380		56,350.00	85,790.00	12 MONTHS	N/A

CONFIDENTIAL

PRICE-LIST
COMPRESSOR-INVERTER SCROLL-R-22 GAS
REFURBISHED



















SRN	MODEL/ NO	MAKE	PRICE		WARRANTY	FREE
			With replacement of Old Compressor	With out replacement of old compressor		
	SCROLL				From date of Billing/In voice	
1	SM-84		13,423.00	22,362.00	12 MONTH S	
2	SM-90		13,423.00	22,362.00	12 MONTH S	
3	SM-100		13,423.00	22,362.00	12 MONTH S	
4	SM-110		17,250.00	28,750.00	12 MONTH S	
5	SM-112		17,250.00	28,750.00	12 MONTH S	
6	SM-120		17,250.00	28,750.00	12 MONTH S	
7	SM-124		17,250.00	28,750.00	12 MONTH S	
8	SM-147		18,400.00	29,900.00	12 MONTH S	N/A
9	SM-148		18,400.00	29,900.00	12 MONTH S	N/A

PRICE-LIST
COMPRESSOR-INVERTER SCROLL-R-22 GAS
REFURBISHED



10	SM-161		19,550.00	31,050.00	12 MONTHS	N/A
11	SM-175		19,550.00	31,050.00	12 MONTHS	N/A
12	SM/SY-185		21,800.00	37,950.00	12 MONTHS	N/A
13	SY-240		46,000.00	74,750.00	12 MONTHS	N/A
14	SY-300		46,000.00	74,750.00	12 MONTHS	N/A
15	SY-380		46,000.00	74,750.00	12 MONTHS	N/A

CONFIDENTIAL

PRICE –LIST
COMPRESSOR –SCROLL-R-407-C GAS
REFURBISHED COMPRESSOR





















SRN	MODEL/NO	MAKE	PRIC E		WARRANTY	FREE
			With replacement of Old Compressor	With out replacement of old compressor		
	COPELAND SCROLL				From date of Billing/Invoice	
1	ZP24K5E		13,225.00	19,550.00	12 MONTHS	
2	ZP28K5E		13,225.00	19,550.00	12 MONTHS	
3	ZP31K5E		13,225.00	19,550.00	12 MONTHS	
4	ZP36K5E		13,225.00	19,550.00	12 MONTHS	
5	ZP42K5E		13,225.00	19,550.00	12 MONTHS	
6	ZP54K5E		13,225.00	19,550.00	12 MONTHS	
7	ZP61K5E		13,225.00	21,850.00	12 MONTHS	
8	ZP72KCE		13,225.00	21,850.00	12 MONTHS	

PRICE –LIST
COMPRESSOR –SCROLL-R-407-C GAS
REFURBISHED COMPRESSOR

9	ZP83KCE		14,375.00	21,850.00	12 MONTHS	
----------	----------------	---	------------------	------------------	------------------	---

CONFIDENTIAL

PRICE –LIST
COMPRESSOR –SCROLL-R-410A-GAS
REFURBISHED COMPRESSOR

SRN	MODEL/NO	MAKE	PRICE		WARRANTY	FREE
	COPELAND SCROLL	Copeland  /EMERSON	With replacement of Old Compressor	With out replacement of old compressor	From date of Billing/Invoice	
1	ZP91KCE		29,900.00	51,750.00	12 MONTHS	
2	ZP104KCE		29,900.00	51,750.00	12 MONTHS	
3	ZP122KCE		31,625.00	51,750.00	12 MONTHS	
4	ZP143KCE		33,925.00	51,750.00	12 MONTHS	
5	ZP154KCE		33,925.00	51,750.00	12 MONTHS	
6	ZP182KCE		40,825.00	51,750.00	12 MONTHS	
7	ZP233KCE		55,200.00	59,800.00	12 MONTHS	
8	ZP293KCE		55,200.00	59,800.00	12 MONTHS	
9	ZP385KCE		55,200.00	59,800.00	12 MONTHS	





















PRICE –LIST
COMPRESSOR –SCROLL-R-410A-GAS
REFURBISHED COMPRESSOR

10	ZP293KZE		55,200.00	59,800.00	12 MONTHS	
11	ZP485KCE		55,200.00	59,800.00	12 MONTHS	
12	ZP725KCE		55,200.00	59,800.00	12 MONTHS	







CONFIDENTIAL



PRICE-LIST
COMPRESSOR-SCROLL R-22GAS
REFURBISHED

SRN	MODEL/NO	MAKE	PRICE		WARRANTY	FREE
	COPELAND SCROLL	 	With replacement of Old Compressor	With out replacement of old compressor	From date of Billing/Invoice	
1	ZR-42		8,050.00	14,375.00	12 MONTHS	
2	ZR-48		8,050.00	14,375.00	12 MONTHS	
3	ZR-57		10,350.00	16,675.00	12 MONTHS	
4	ZR-61		10,350.00	16,675.00	12 MONTHS	
5	ZR-72		10,350.00	16,675.00	12 MONTHS	
6	ZR-81		21,850.00	46,000.00	12 MONTHS	
7	ZR-108		23,000.00	46,000.00	12 MONTHS	
8	ZR-125		23,000.00	46,000.00	12 MONTHS	
9	ZR-144		25,300.00	48,300.00	12 MONTHS	







**PRICE-LIST
COMPRESSOR-SCROLL R-22GAS
REFURBISHED**

10	ZR-160		25,300.00	43,700.00	12 MONTHS	
11	ZR-190		32,200.00	48,300.00	12 MONTHS	
12	ZR-295		46,000.00	74,750.00	12 MONTHS	N/A
13	ZR-310		46,000.00	74,750.00	12 MONTHS	N/A

CONFIDENTIAL



PRICE-LIST
COMPRESSOR-INVERTER
SCROLL- R-410A
REFURBISHED COMPRESSOR

SRN	MODEL/NO	MAKE	PRICE		WARRANTY	FREE
	INVERTERS CROLL		With replacement of Old Compressor	With out replacement of old compressor	From date of Billing/Invoice	
1	JT-1GCVDKYR-7525		28,750.00	46,000.00	12 MONTHS	N/A
2	JT-1GCVDYR@T		28,750.00	46,000.00	12 MONTHS	N/A
3	JT-15JBVDKYR@T		28,750.00	46,000.00	12 MONTHS	N/A
4	JT-16KCVDYR@TF		28,750.00	46,000.00	12 MONTHS	N/A
5	JT-1GUVDYR@TF		28,750.00	46,000.00	12 MONTHS	N/A



PRICE-LIST
COMPRESSOR-INVERTER
SCROLL-R-410A
REFURBISHED COMPRESSOR



SRN	MODEL/NO	MAKE	PRICE		WARRANTY	FREE
			With replacement of Old Compressor	With out replacement of old compressor		
	INVERTER SCROLL				From date of Billing/Invoice	
1	HNB84FC1-Y		28,750.00	46,000.00	12 MONTHS	N/A
2	HNB84FC1-YE-C		28,750.00	46,000.00	12 MONTHS	N/A
3	ANB52FYD MT		28,750.00	46,000.00	12 MONTHS	N/A

Note: All Models Inverter compressors are available









CONFIDENTIAL





PRICE-LIST
COMPRESSOR- INVERTER
SCROLL R-410A
REFURBISHED COMPRESSOR

SRN	MODEL/NO	MAKE	PRICE		WARRANTY	FREE
	INVERTER SCROLL	HITACHI	With replacement of Old Compressor	With out replacement of old compressor	From date of Billing/Invoice	
1	DA65PHD- D1YZ		28,750.00	46,000.00	12 MONTHS	N/A



CONFIDENTIAL

SRN	MODEL NO	REFRIGERANT	MAKE	TR	WEIGHT	MODEL	LP- WITH REPLACEMENT OF DEFECTIVE COMPRESSOR	LP- WITHOUT REPLACEMENT
1	SM084	R22	DANFOSS	7	64		13,423.00	22,362.00
2	SM090	R22	DANFOSS	7.5	65		13,423.00	22,362.00
3	SM100	R22	DANFOSS	8	65		13,423.00	22,362.00
4	SM110	R22	DANFOSS	9	73		17,250.00	28,750.00
5	SM112	R22	DANFOSS	10	64		17,250.00	28,750.00
6	SM120/124	R22	DANFOSS	10.5	73		17,250.00	28,750.00
7	SM147	R22	DANFOSS	12	64		18,400.00	29,900.00
8	SM148	R22	DANFOSS	12	67		18,400.00	29,900.00
9	SM161	R22	DANFOSS	13	88		19,550.00	31,050.00











10	SM175	R22	DANFOSS	14	88		19,550.00	31,050.00
11	SM185	R22	DANFOSS	15	100		21,800.00	37,950.00





LIST PRICE-SZ R-407 GAS REFURBISHED COMPRESSOR 1 YEAR WARRANTY +DRIER FREE

SRN	MODEL NO	REFRIGERANT	MAKE	TR	WEIGHT	MODEL	LP- WITH REPLACEMENT OF DEFECTIVE COMPRESSOR	LP- WITHOUT REPLACEMENT
1	SZ084	R407C	DANFOSS	7	64		17,534.00	25,584.00
2	SZ090	R407C	DANFOSS	7.5	65		18,615.00	27,240.00
3	SZ100	R407C	DANFOSS	8	65		19,696.00	28,896.00
4	SZ110	R407C	DANFOSS	9	73		24.020.00	35,520.00
5	SZ112	R407C	DANFOSS	10	64		24.020.00	35,520.00
6	SZ120	R407C	DANFOSS	10.5	73		24.020.00	35,520.00
7	SZ148	R407C	DANFOSS	12	67		25,700.00	36,670.00

8	SZ161	R407C	DANFOSS	13	88		28,720.00	49,420.00
9	SZ175	R407C	DANFOSS	14	88		28,720.00	49,420.00
10	SZ185	R407C	DANFOSS	15	100		34,930.00	51,030.00
11	SZ240	R407C	DANFOSS	20	150		62,750.00	92,190.00
12	SZ300	R407C	DANFOSS	25	157		62,750.00	92,190.00
13	SZ380	R407C	DANFOSS	30	158		63,150.00	92,590.00

SRN	MODEL NO	REFRIGERANT R22	MAKE	TR	WEIGHT	MODEL IMAGE	LP- WITH REPLACEMENT OF DEFECTIVE COMPRESSOR	LP- WITHOUT REPLACEMENT
1	ZR42K3	R22	COPELAND	3.5	28		8,050.00	14,375.00
2	ZR44K5	R22	COPELAND	3.7	28		8,050.00	14,375.00
3	ZR45KC	R22	COPELAND	3.8	28		8,050.00	14,375.00
4	ZR47KC	R22	COPELAND	3.9	28		8,050.00	14,375.00
5	ZR48KC	R22	COPELAND	4	29		8,500.00	14,375.00
6	ZR54KE	R22	COPELAND	4.5	29		8,050.00	14,375.00
7	ZR54KS	R22	COPELAND	4.5	28		8,050.00	14,375.00
8	ZR57KE	R22	COPELAND	4.8	28		10,400.00	16,800.00
9	ZR57KS	R22	COPELAND	4.8	30		10,400.00	16,800.00
10	ZR61KE	R22	COPELAND	5.1	29		10,400.00	16,800.00

11	ZR61KS	R22	COPELAND	5.1	29		10,400.00	16,800.00
12	ZR68KC	R22	COPELAND	5.7	38		10,400.00	16,800.00
13	ZR72KC	R22	COPELAND	6	38		10,400.00	16,800.00
14	ZR81KC	R22	COPELAND	6.8	39		10,400.00	16,800.00
15	ZR84KC	R22	COPELAND	7	57		10,400.00	16,800.00
16	ZR94KC	R22	COPELAND	7.8	57		23,000.00	46,000.00
17	ZR108KC	R22	COPELAND	9	60		23,000.00	46,000.00
18	ZR125KC	R22	COPELAND	10	61		23,000.00	46,000.00
19	ZR144KC	R22	COPELAND	12	61		25,300.00	48,300.00
20	ZR160KC	R22	COPELAND	13.3	64		25,300.00	48,700.00

21	ZR190KC	R22	COPELAND	15.8	66		32,200.00	48,700.00
22	ZR250KC	R22	COPELAND	20.8	139		46,000.00	74,750.00
23	ZR295KC	R22	COPELAND	20.8	139		46,000.00	74,750.00
24	ZR310KC	R22	COPELAND	25.8	160		46,000.00	74,750.00
25	ZR380KC	R22	COPELAND	31	176		46,000.00	74,750.00